

Assembly instructions

TerraWing Foundation System



Thank you for choosing the TerraWing Foundation System for your application!

By the time you read this, you will probably soon be installing your foundation and will therefore need some information about the system, how it functions, what you can expect, and what it might be good to think about for the foundation.

The TerraWing Foundation System has been available on the market since 2003. More than 104 000 foundations have been applied over the years. The benefits are:

- Project planning in accordance with Eurocode, complete documentation included in the delivery
- Fast and simple application in the terrain, normal capacity is 5-15 foundations/hour depending on geotechnics
- Overall cost-effectiveness, high quality in CE-marked production plants

Take a few minutes to read through this pamphlet to ensure that the system is maximally utilised and that the application in the field is quick and easy. Don't hesitate to contact us if you have any queries.

Good luck with your foundation!

To think about...

...before you start the application in the field

How is the TerraWing Foundation System structured?

The TerraWing Foundation System consists in practice of a steel structure containing a pipe section with wings adapted to loads and geotechnical conditions. Above these is TerraWing's patented adjusting device consisting of a boom, and an adjusting plate with a centre bolt and corner bolts for connection to the post base.

TerraWing can also supply posts for your object. If you procure poles from elsewhere, bear in mind that the pole's base plate must fit the foundation's adjusting plate with the right length, width and thickness dimensions, bolt pattern, and bolt size. Contact us for drawing of a suitable post base.

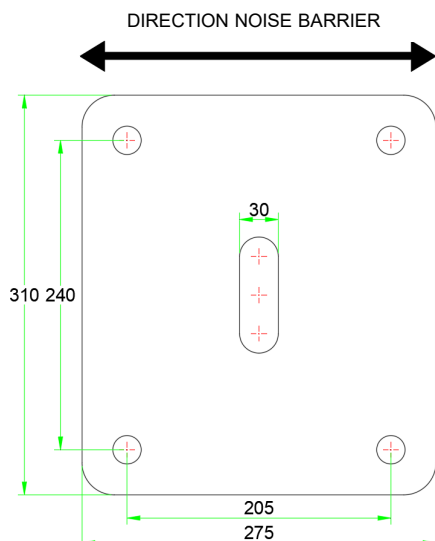

- ✓ Follow the assembly / foundation plan precisely. If incorrect accessories are installed the post will not fit
- ✓ Holes and c/c (center-distance) are different for different adjusting plates, be observant, check the marking
- ✓ Slots on adjusting plate perpendicular to barrier
- ✓ Secure tape measure in position 0 and measure 50 metres at a time, avoid compounding errors
- ✓ Trimming allowance in the foundation across the barrier ± 30 mm
- ✓ Trimming allowance in post base across the barrier ± 15 mm
- ✓ Trimming allowance in the foundation along the barrier ± 45 mm
- ✓ Trimming allowance in post base along the barrier ± 0 mm

Do I need a foundation plan?

In its simplest and most functional form, a foundation plan is a calculation sheet in a program such as Excel. The information is presented in matrix form with each foundation position constituting a line with information such as screen height, c/c between posts, foundation type, adjusting plate, boom type, centre bolt, bolt set and post base.



Objekt Bullervägen

position	post length	c/c	post type	foot plate	tightening corner bolt	Foundation	adjusting Plate	adjusting boom	center bolt	angled tightening centerbolt	bolt set
S1	3600	3000	HEA180	F82t25	520Nm	M94N L25	P293t35	B94	C3035	142°	S27254
S2	3600	3000	HEA180	F82t25	520Nm	M94N L25	P293t35	B94	C3035	142°	S27254
S3	3600	3000	HEA180	F82t25	520Nm	M94N L25	P293t35	B94	C3035	142°	S27254
S4	3600	3000	HEA180	F82t25	520Nm	M94N L25	P293t35	B94	C3035	142°	S27254
S5	3600	3000	HEA180	F82t25	520Nm	M94N L25	P293t35	B94	C3035	142°	S27254
S6	3600	3000	HEA180	F82t25	520Nm	M94N L25	P293t35	B94	C3035	142°	S27254
S7	3600	3000	HEA180	F82t25	520Nm	M94N L25	P293t35	B94	C3035	142°	S27254
S8	3600	3000	HEA180	F82t25	520Nm	M94N L25	P293t35	B94	C3035	142°	S27254
S9	3600	3000	HEA180	F82t25	520Nm	M94N L25	P282t30	B94	C3035	142°	S27254
S10	3600	3000	HEA180	F82t25	520Nm	M94N L25	P282t30	B94	C3035	142°	S27254
S11	3600	3000	HEA180	F82t25	520Nm	M94N L25	P282t30	B94	C3035	142°	S27254
S12	3600	3000	HEA180	F82t25	520Nm	M94N L25	P282t30	B94	C3035	142°	S27254
S13	3600	3000	HEA180	F82t25	520Nm	M94N L25	P282t30	B94	C3035	142°	S27254
S14	3600	3000	HEA180	F82t25	520Nm	M94N L25	P282t30	B94	C3035	142°	S27254
S15	3600	3000	HEA180	F82t25	520Nm	M94N L25	P282t30	B94	C3035	142°	S27254
S16	3600	3000	HEA180	F82t25	520Nm	M94N L25	P282t30	B94	C3035	142°	S27254

A foundation plan is a good way to:

- Plan which foundations should be where on the building site
- Simplify installation of the right accessories for the respective foundation type
- Document and quality assure what has been done

A well thought-out foundation plan can deliver higher capacity when knocking posts down.

TerraWing recommends that a foundation plan is always prepared.

Delivery of foundations from the factory

TerraWing notifies the delivery a few days before the delivery date. Delivery is normally with a carrier such as DHL, with which we have a freight contract, or direct delivery from our manufacturer in the Baltic States.

Some of our drivers have limited language skills.



In the event of any queries concerning your delivery please contact:

*TerraWing AB
Gasverksvägen 15
611 35 Nyköping
Phone: 0155-21 77 70
E-mail: info@terrawing.se*

To achieve high capacity when knocking the foundations in, a foundation plan should have been prepared containing height of each individual foundation, type of foundation, as well as accessories for each position. The foundation should be located in the respective location where it is to be knocked in.

The working party should ideally consist of a machine and driver, along with an additional person to assist with handling and direction of the foundation. Be careful to position the foundation correctly in height and level, for strength reasons the distance between adjusting plate and post base should be as small as possible after installation.

Fine adjustment of c/c distance and lateral position is with our patented adjustment device.



Which equipment do I need...



...Tracked machine with hydraulic hammer or alternatively alternative excavator with hydraulic hammer used for knocking down

Using the TerraWing Foundation System entails minimal handling of soil. The capacity for knocking down foundations is normally 5-15 foundations per hour depending on geotechnics, size and type of foundations and equipment.

TerraWing collaborates with Bopec Väst AB. Bopec has lorries equipped with hydraulic hammers which reach about 3m from the roadside. Bopec also has specialised tracked machines equipped with hydraulic hammers.



To book Bopec for your project call
+46 (0)304-45190



The pike and its parts

The pike prepares the route for the foundation. The pike should be about 10 cm longer than the foundation

With hard ground conditions such as boulder moraine/rocky banks, it is recommended that the pike is first driven in to its full length and the foundation subsequently mounted on the pike for insertion.

It is important to lubricate the surface between the chisel and the pike with grease.

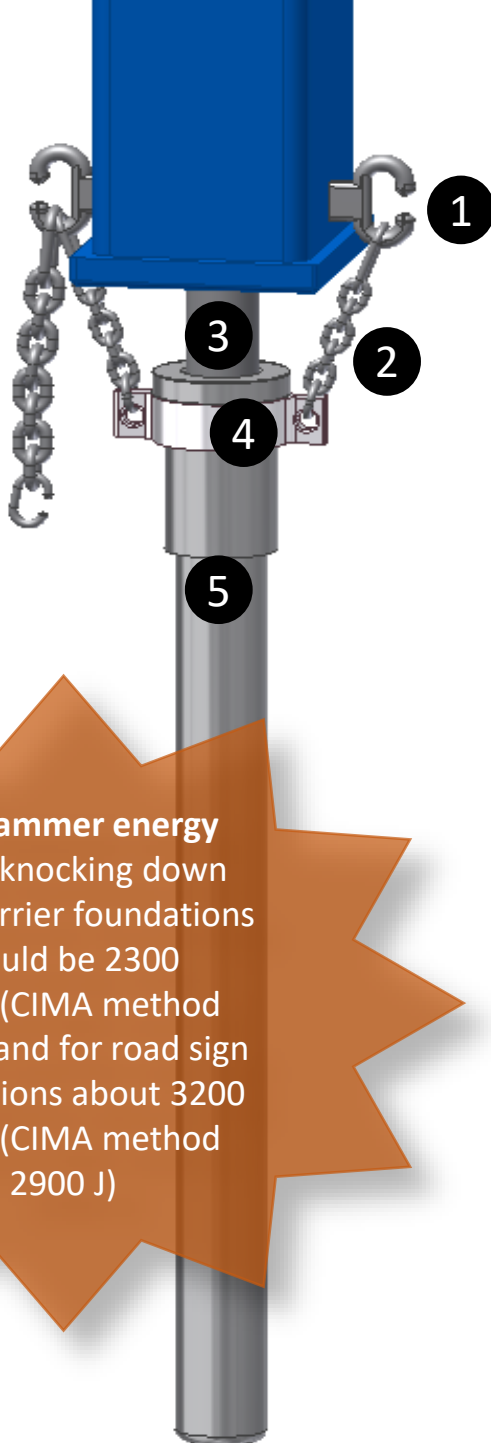

- 1 Lugs
For suspension of pike
- 2 Drag chain
Provided by operator
- 3 Chisel
Diameter 100-115 mm
- 4 Draw ring
Included in rental of pike
- 5 Pike
Available for rent

The hammer energy
When knocking down noise barrier foundations should be 2300 Joules(CIMA method 1500 J) and for road sign foundations about 3200 Joules(CIMA method 2900 J)

Pikes are available to rent from TerraWing in the lengths 1600 mm and 2100 mm. The following rules apply for TerraWing's rental pikes:

- ✓ Diameter chisel 100-115 mm (chisel dimension over 115mm results in chisel and pike merging)
- ✓ Chisel length minimum 255 mm (is needed for clearance against pike edge)
- ✓ The chisel must have a flat end (risk of cantilevering and merging)

Knocking down foundations

...to achieve Industrial efficiency in the terrain

When knocking in light foundations that can be raised by hand, the foundation is raised and the pike is inserted down in the foundation. The lifting hooks are then secured in the holes in the wings and the foundation is lifted into place.



For heavier foundations, the pike is secured in the foundation when the foundation is lying on the ground. The plate lock is then secured in a wing and the foundation is lifted into place.

The capacity can normally increase to 5-15 foundations/hour depending on size of the foundation and prevailing geotechnics.

With rocky banks and boulder moraine, the pike should first be knocked down to the right depth on its own, after which the foundation is threaded on and driven down..

It is important that the noise-reducing screen is tight against the ground. It has major importance for the screen's noise-suppressing capacity.

You can choose to add soil to seal below the noise-reducing screen after it is mounted.

Always try to complete that the ground level is in level with the top edge of the baseplate

You can also choose to make an approximately 40 cm wide and 30 cm depth gulley using a cable bucket.

The soil is placed at the edge of the gulley and used to backfill around the screen.





Secure a tape measure with, for example, a screw clamp in the first foundation inserted and carefully measure the c/c distance to subsequent foundations.

Use GPS, pipe laser or a line to set out direction of the foundation.

It is a good idea to install the pin bolts in the mounting plate in a workshop where you have access to an impact wrench.

Adjust the adjusting plates and then loosely tighten the centre bolts. When you are satisfied with the position, tighten the centre bolts according to the following pages in the assembly instructions.



Mounting of accessories

Angular tightening of the centrum bolt

After adjustment the centrum bolt is pulled fully for contact between the parts. Thereafter the bolt angle specified in the documentation that arrives together with the delivery of the foundations. The angle is different for various foundations, plate thicknesses, bolt dimensions and bolt lengths.

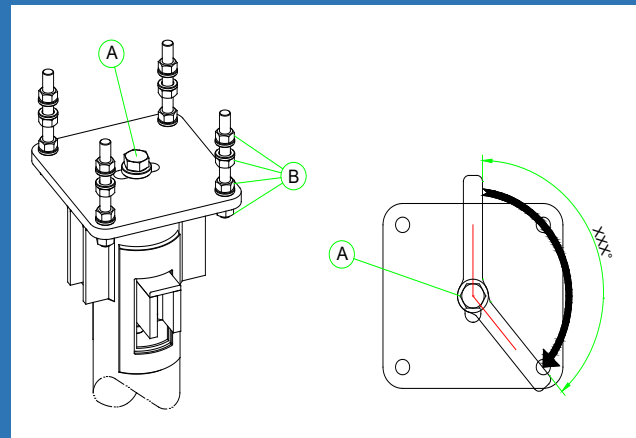

Angle routing can be done by hand or machine, the main thing is that the correct angle is achieved: :

1. Make a pencil mark on the plate and on the bolt as positioning mark before tightening
2. Mät därefter upp angiven vinkel och göra ny märkning med penna



Tighten the bolt from mark 1 to 2 above

Angle routing provides a bias that is necessary for a full function of the foundation

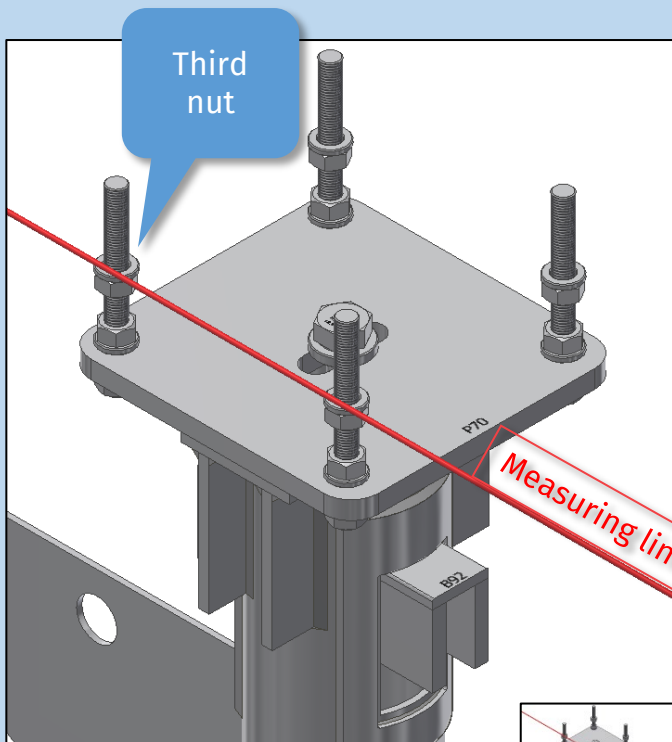

Adjustment of the correct height before mounting the post.

Start by adjusting an optional pin bolt per foundation. Calibrate the third nut on the pin bolt using a calibrator.

Then lock the nut with LOCTITE 243 and for safety's sake, make a mark with a felt tip pen.

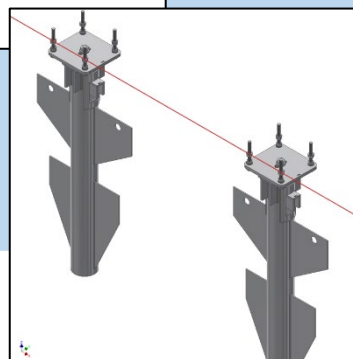

Now continue to adjust the third nut on the other pin bolts with the starting point from the first pin bolt. Use a small spirit level for this. Remember to put a washer above the nut before you put the post on. When the post is in place, tighten the nuts to the required torque and lock with LOCTITE 243 or alternatively a centre punch mark of the thread as thread lock. Installation of the screen can now commence.

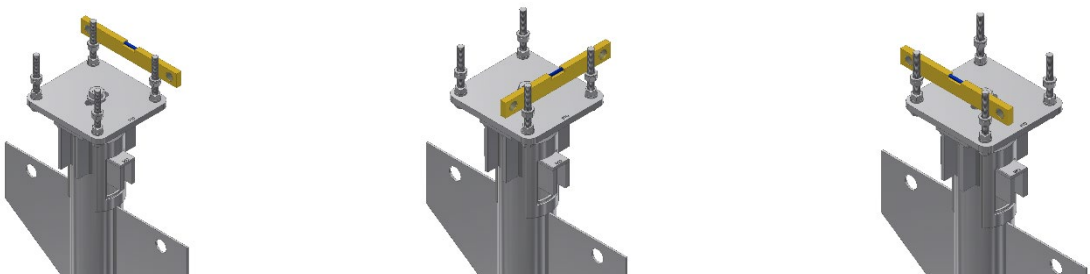

Tightening of pin bolts to posts

In connection with installing the posts, the pin bolts should be tightened using torquing. The torque specified in the table below can be achieved through use of a sleeve with the lever specified.

Tightening should be with the "strength of a man". According to the table below this is about 600 Nm with a 1 metre lever. In other words, this is equivalent to about 60 kg tightening with the lever.

Bolt - dimension (mm)	Lever's length with manual tightening		Torque when tightening (Nm)	
	Bolt in delivery condition	Waxed bolt	Bolt in delivery condition	Waxed bolt
20	500mm	300mm	350Nm	210Nm
24	1000mm	600mm	600Nm	350Nm
27	1500mm	900mm	900Nm	550Nm
30	2000mm	1300mm	1250Nm	750Nm
36		2400mm	2350Nm	1400Nm



TerraWing Foundation System

TerraWing Foundation system has been on the market since 2003. More than 104 000 foundations has been applied during these years. The benefits are:

- Projecting according to Eurocode, complete documentation is included in the delivery
- Fast and simple application in the terrain, normal capacity is 5-15 foundations/hour depending on geotechnics
- Total cost efficiency, high quality in CE-marked fabrics

Dimensions and constructions of the foundations is calculated with TerraWing's calculation program adapted to Eurocode. Together with the delivery of the foundation following a extensive calculation document. Keep in mind that we have your tender documentation as the basis for all the calculations of the foundations!

TerraWing AB
Gasverksvägen 15
611 35 Nyköping
0155-21 77 70
www.terrawing.se